

第 31 回日本遺伝子細胞治療学会学術集会

The 31st Annual Meeting of the Japan Society of Gene and Cell Therapy

Prospectus

- Period : July 23 (Wed) to July 25 (Fri), 2025
With Educational programs (in the Institute of Medical Science) on July 22nd
- Venue : Hotel Gajoen Tokyo (Meguro-ku, Tokyo)
- Chairperson : Takashi Okada, M.D., Ph.D., DipWSET
(Professor at the Institute of Medical Science, the University of Tokyo)
- Organizer : Japan Society of Gene and Cell Therapy, GIA

Contents

Greetings	P. 3
Breakdown of Income and Expenditure Budget	P. 4
Sponsorship Donation Guidelines	P. 5 - 7
Application Guidelines for Co-sponsored Seminars	P. 8 - 9
Corporate Exhibition Guidelines	P. 10 - 11
Requests for Advertising in the Pocket Program	P. 12 - 13
Requests for Banner Advertisements on the Conference Website	P. 14
Intermission Commercial Broadcast Recruitment Guidelines	P. 15
Name Card Holder & Strap Sponsorship Guidelines	P. 16
Floor Plan of the Venue (proposed use of the venue)	P. 17
Application Forms	P. 18 - 23

Greetings

Dear Colleagues, we wish you continued prosperity in the future. We would also like to express our sincere gratitude for your continued understanding and cooperation.

We are pleased to announce that the 31st Annual Meeting of the Japanese Society for Gene and Cell Therapy (JSGCT2025) will be held at Hotel Gajoen Tokyo in Meguro-ku, Tokyo for three days* from July 23 (Wed) to July 25 (Fri), 2025. The theme of this conference is "International Contribution and the Dawn of a New Era."

*The educational program will be held on Tuesday, March 22 (Location: the Institute of Medical Science, the University of Tokyo).

Gene therapy has attracted considerable attention owing to its distinct mechanism of action and clinical efficacy based on the molecular pathology. Gene therapy products for cancer and hereditary diseases are being rapidly commercialized, with marketing approvals increasing in number in Japan and especially in Europe and the USA, and various clinical trials are being conducted. In the field of cell therapy, progress is being made in the development of next-generation mesenchymal cells using high-performance designer cells and fetal appendages, and various modalities are expected to be developed depending on the pathological condition.

However, with gains in experience, various problems have come to light, such as adverse events associated with large-scale systemic administration, stagnation in product development in Japan, and a shortage of research personnel. Therefore, the need to leverage real-world information and develop globally applicable technologies that reflect this information is ongoing.

For this reason, it is necessary to promote the overseas expansion of domestic technologies while actively participating in tripartite information exchanges among Japan, USA, and Europe as well as fostering international cooperation among regulatory authorities. In recent years, the number of corporate participants has increased, making conferences an important forum for exchanges among industry, government, and academia. As part of our efforts to proactively disseminate information about Japan's excellent seeds and their future potential for society, we look forward to being able to welcome representatives from the American Society for Gene and Cell Therapy and regulatory authorities to this academic conference.

Therefore, we would like to invite you to apply for co-sponsorship, exhibition, advertisement, and other opportunities at this meeting and would appreciate your understanding and cooperation regarding the various application stipulations.

Finally, I wish for your continued success.

Sincerely yours,

July 2024

The 31st Annual Meeting of the Japanese Society
of Gene and Cell Therapy
Chairperson: Takashi Okada, M.D., Ph.D., Dip.WSET
(Professor, the Institute of Medical Science, the University of Tokyo)



Breakdown of Income and Expenditure Budget

1. Income	(In JPY)
Participation fee	15,450,000
<small>(Members: Pre-registration 12,000 yen × 150 people; On-site registration 15,000 yen × 100 people) (Non-members: Pre-registration 20,000 yen × 300 people; On-site registration 30,000 yen × 100 people) (Graduate students: 3,000 yen × 50 people; Students: 0 yen × 50 people; Enterprises: 30,000 yen × 100 people) (Staff: 0 yen × 150 people)</small>	
Get-together (3,000 yen × 100 people)	300,000
Social gathering (6,000 yen × 100 people)	600,000
Co-sponsored seminars	36,960,000
<small>(Morning seminars: 880,000 yen × 2 slots; 770,000 yen × 2 slots; 660,000 yen × 2 slots) (Luncheon seminars: 2,530,000 yen × 3 slots; 1,870,000 yen × 3 slots; 1,650,000 yen × 3 slots) (Afternoon seminars: 1,320,000 yen × 3 slots; 990,000 yen × 3 slots; 880,000yen × 3 slots) (Evening seminars: 880,000 yen × 2 slots; 770,000 yen × 2 slots; 660,000 yen × 2 slots)</small>	
Corporate exhibitions (275,000 yen × 31 booths)	8,525,000
Advertisement (220,000 yen × 1 slot; 165,000 yen × 2 slots; 110,000 yen × 5 slots; 77,000 yen × 5 slots)	1,485,000
Banner advertising (110,000 yen × 6 slots)	660,000
Intermission commercials (165,000 yen × 5 slots)	825,000
Name card holders & straps (330,000 yen × 1 slot)	330,000
Donations	3,815,000
<hr/>	
Total (tax included)	68,950,000
2. Expenditures	(In JPY)
Secretariat expenses (management fees)	3,500,000
Advanced preparation fees (homepage, registration, abstract registry, etc.)	900,000
Venue fee	35,000,000
On-site operating expenses (video equipment, labor costs, etc.)	8,500,000
Construction, signage, and decoration costs	3,100,000
Invitation and reception expenses	6,600,000
Printing-related expenses (envelopes, posters, pocket programs, etc.)	2,200,000
Abstract app	1,650,000
Communication costs (postage, etc.)	300,000
Contingency funds (tax payment reserve, etc.)	3,500,000
Food and beverage expenses	900,000
Incidentals	2,800,000
<hr/>	
Total (tax included)	68,950,000

Sponsorship Donation Guidelines

1. Name of meeting: The 31st Annual Meeting of the Japan Society of Gene and Cell Therapy
2. Period: July 23 (Wed) to July 25 (Fri), 2025
3. Venue: Hotel Gajoen Tokyo
(1-8-1 Shimomeguro, Meguro-ku, Tokyo 153-0064; Tel: 03-3491-4111)
4. Chairperson: Okada Takashi (Professor at the Institute of Medical Science, the University of Tokyo)
5. Planned number of participants: Approx. 1,000 people

6. Participation fees:

Classification	Pre-registration	On-site registration
Academia / members	10,000 yen	15,000 yen
Academia / non-members	22,000 yen	30,000 yen
Graduate students	3,000 yen	
Students (Undergraduates)	Free	
Companies / members	30,000 yen per person · 70,000 yen per 3 persons	
Corporate / non-members	40,000 yen per person · 100,000 yen per 3 persons	

7. Organizer: Japan Society of Gene and Cell Therapy, General Incorporated Association (GIA)
8. Incorporation: Please refer to the website of the Japan Society of Gene and Cell Therapy, GIA
<https://www.jsgct.jp/about/regulation/>
9. Organization (Board of Directors): Please refer to the website of the Japan Society of Gene and Cell Therapy, GIA
<https://www.jsgct.jp/about/member/>
10. Meeting secretariat: The Institute of Medical Science, the University of Tokyo, Center for Gene & Cell Therapy, Division of Medical & Molecular Genetics
4-6-1 Shirokanedai, Minato-ku, Tokyo 108-8639
Tel: 03-5449-5372 (extension: 75372); Fax: 03-5449-5529
11. Meeting management secretariat: Do Convention Inc.
5F, Access Ochanomizu Buidling, 2-23 Kanda-Awaji-cho, Chiyoda-ku, Tokyo 01-0063
Tel: 03-5289-7717; Fax: 03-5289-8117
E-mail: jsgct2025-office@umin.ac.jp
12. Meeting homepage: <http://jsgct2025.umin.ne.jp>

13. Program (tentative):

※Double-underlined items are programs co-sponsored by companies.

MS = Morning Seminar; LS = Luncheon Seminar; AS = Afternoon Seminar; ES = Evening Seminar

7/22 (Tue)	(Morning)	(Noon)	(Afternoon)
IMSUT	JSGCT Educational Programs 2025		
Room 1	—	—	Setup & preparation
Room 2	—	—	Setup & preparation
Room 3	—	—	Setup & preparation
Exhibition hall	—	—	Setup & preparation
7/23 (Wed)	(Morning)	(Noon)	(Afternoon)
Room 1	Opening, special events, etc.	<u>LS1</u>	<u>AS1</u> , special events, etc. <u>ES1</u>
Room 2	Symposia, panels	<u>LS2</u>	<u>AS2</u> , symposia, panels, <u>ES2</u>
Room 3	General presentations	<u>LS3</u>	<u>AS3</u> , general presentations, <u>ES3</u>
Exhibition hall	Corporate exhibitions		
7/24 (Thu)	(Morning)	(Noon)	(Afternoon)
Room 1	<u>MS1</u> , special events, etc.	<u>LS4</u>	<u>AS4</u> , special events, etc. <u>ES4</u>
Room 2	<u>MS2</u> , symposia, panels	<u>LS5</u>	<u>AS5</u> , symposia, panels, <u>ES5</u>
Room 3	<u>MS3</u> , general presentations	<u>LS6</u>	<u>AS6</u> , general presentations, <u>ES6</u>
Exhibition hall	Corporate exhibitions		
7/25 (Fri)	(Morning)	(Noon)	(Afternoon)
Room 1	<u>MS4</u> , special events, etc.	<u>LS7</u>	<u>AS7</u> , special events, etc., closing
Room 2	<u>MS5</u> , symposia, panels	<u>LS8</u>	<u>AS8</u> , symposia, panels
Room 3	<u>MS6</u> , general presentations	<u>LS9</u>	<u>AS9</u> , general presentations
Exhibition hall	Corporate exhibitions		

14. Proposed use of the venue:

Venue	Floor	Room name	Use	Area	Number of seats planned (theater format)
Room 1	2F	Maiougi	Oral presentations	838 m ²	Approx. 600 seats
Room 2	2F	Hanashizuka	Oral presentations	249 m ²	Approx. 200 seats
Room 3	2F	Hanashirabe	Oral presentations	198 m ²	Approx. 160 seats
Exhibition hall	2F	Hanatsudo	Corporate exhibitions	502 m ²	31 booths or more
General reception	2F	2F Foyer	—	—	—

15. Donation guidelines:

- 1) Name of fundraising: The 31st Annual Meeting of the Japan Society of Gene and Cell Therapy
- 2) Purpose of fundraiser: To support the operation of the 31st Annual Meeting of the Japan Society of Gene and Cell Therapy
- 3) Fundraising target: 3,815,000 yen
- 4) Fundraising period : July 12 (Fri), 2024 to July 21 (Mon), 2025
- 5) Payment account : Resona Bank, Limited
 SWIFT code: 【DIWAJPJT】
 MEGURO-EKIMAE Branch (518)
 Account number: 2129156
 3-2-1 Kamiohsaki, Shinagawa-ku, Tokyo, JAPAN
 The 31st Annual Meeting of the Japan Society of Gene and Cell Therapy
 4-6-1 Shirokanedai, Minato-ku, Tokyo, JAPAN
 Chairperson: Takashi Okada
- 6) Without tax exemptions.
- 7) Qualified Invoicing Business Registration Number: T3010405020201

How to apply: Please send the attached application form by e-mail.

Donation benefits:

For every 1 unit of donation (100,000 yen), donors will be given one certificate of participation in the academic meeting free of charge. Additionally, for corporations donating five units (500,000 yen) or more, the donor company's advertisement will be projected onto the main screen of each oral venue during intermissions.

※Based on the "Guidelines for Transparency in the Relationship between Corporate Activities and Medical Institutions, etc." set out by the Japan Pharmaceutical Manufacturers Association and the Japan Federation of Medical Devices Associations, your company agrees that the costs associated with holding academic conferences and other meetings will be published on your company's website under the name of the academic conference or co-sponsored seminar.

※We will donate the program to companies that sponsor the event.

※The payment receipt will be the transfer certificate issued by the bank.

※Please note that your company will be responsible for the bank transfer fee.

Application Guidelines for Co-sponsored Seminars

1. Date: From July 23 (Wed) to July 25 (Fri), 2025
2. Venue: Hotel Gajoen Tokyo
(1-8-1 Shimomeguro, Meguro-ku, Tokyo 153-0064; Tel: 03-3491-4111)
3. Seminar co-sponsorship fees:

Date	Time (planned)	Venue	Code	Seminar name	Seats (approx.) Theater format	共催費 (税込)
7/23 (Wed)	12:00 13:00	Room 1	LS1	Luncheon Seminar 1	600 seats	2,530,000 yen
		Room 2	LS2	Luncheon Seminar 2	200 seats	1,870,000 yen
		Room 3	LS3	Luncheon Seminar 3	160 seats	1,650,000 yen
	Afternoon (45 min.)	Room 1	AS1	Afternoon Seminar 1	600 seats	1,320,000 yen
		Room 2	AS2	Afternoon Seminar 2	200 seats	990,000 yen
		Room 3	AS3	Afternoon Seminar 3	160 seats	880,000 yen
	Evening (45 min.)	Room 1	ES1	Evening Seminar 1	600 seats	880,000 yen
		Room 2	ES2	Evening Seminar 2	200 seats	770,000 yen
		Room 3	ES3	Evening Seminar 3	160 seats	660,000 yen
7/24 (Thu)	Morning (45 min.)	Room 1	MS1	Morning Seminar 1	600 seats	880,000 yen
		Room 2	MS2	Morning Seminar 2	200 seats	770,000 yen
		Room 3	MS3	Morning Seminar 3	160 seats	660,000 yen
	12:00 13:00	Room 1	LS4	Luncheon Seminar 4	600 seats	2,530,000 yen
		Room 2	LS5	Luncheon Seminar 5	200 seats	1,870,000 yen
		Room 3	LS6	Luncheon Seminar 6	160 seats	1,650,000 yen
	Afternoon (45 min.)	Room 1	AS4	Afternoon Seminar 4	600 seats	1,320,000 yen
		Room 2	AS5	Afternoon Seminar 5	200 seats	990,000 yen
		Room 3	AS6	Afternoon Seminar 6	160 seats	880,000 yen
	Evening (45 min.)	Room 1	ES4	Evening Seminar 4	600 seats	880,000 yen
		Room 2	ES5	Evening Seminar 5	200 seats	770,000 yen
		Room 3	ES6	Evening Seminar 6	160 seats	660,000 yen
7/25 (Fri)	Morning (45 min.)	Room 1	MS4	Morning Seminar 4	600 seats	880,000 yen
		Room 2	MS5	Morning Seminar 5	200 seats	770,000 yen
		Room 3	MS6	Morning Seminar 6	160 seats	660,000 yen
	12:00 13:00	Room 1	LS7	Luncheon Seminar 7	600 seats	2,530,000 yen
		Room 2	LS8	Luncheon Seminar 8	200 seats	1,870,000 yen
		Room 3	LS9	Luncheon Seminar 9	160 seats	1,650,000 yen
	Afternoon (45 min.)	Room 1	AS7	Afternoon Seminar 7	600 seats	1,320,000 yen
		Room 2	AS8	Afternoon Seminar 8	200 seats	990,000 yen
		Room 3	AS9	Afternoon Seminar 9	160 seats	880,000 yen

☆Included in the co-organizer fee: venue fee, waiting room fee, seminar display board, PC operator, set of presentation equipment

☆Not included in the co-sponsorship fee: gratuities/travel/accommodation/food and beverage expenses for speakers and chairpersons; lunch boxes or refreshments* for facilitators, lighting staff, and participants;

beverage expenses; and staff expenses for distribution and collection of materials, etc.

(*) Co-sponsors will be required to cover the costs of packed lunches for luncheon seminars and the costs of snacks (tea and sweets) for morning, afternoon, and evening seminars.

☆ The types of food and beverages provided will be left to the discretion of the tournament secretariat, but the quantity to be ordered will be decided by your company.

For details, please refer to the "Joint Seminar Management Guidelines" that will be distributed approximately one month before the event.

4. How and when to apply: Please send the attached application form via e-mail by no later than April 30 (Wed), 2025.

※The seminar theme, speakers, and Chairperson will be decided in consultation with the organizer and co-hosting companies. Please indicate your first, second, and third choices.

5. Abstract, Speaker, and Chairperson submissions: Please send Abstract, Speaker, and Chairperson information to the secretariat via e-mail by no later than April 30 (Wed), 2025.

6. Seminar flyers: Co-sponsors are free to choose whether to create a seminar flyer and the size, color, and number of copies to be distributed. The flyer content will be confirmed in advance by the management office. Therefore, please send a PDF file to the management office via email before printing. Please include the Society logo (provided by the management office).

7. Disclaimer: In the event that the above-mentioned meeting is affected by natural disasters or other reasons beyond the organizers' control, we may ask you to adjust your sponsorship details and costs.

Contact: Secretariat of the 31st Annual Meeting of the Japan Society of Gene and Cell Therapy

Do Convention Inc.

5F, Access Ochanomizu Building, 2-23 Kanda-Awaji-cho, Chiyoda-ku, Tokyo 101-0063

E-mail: jsgct2025-office@umin.ac.jp

Person in charge: Daisuke Kurauchi

8. Payment account: Resona Bank, Limited
SWIFT code: 【DIWAJPJT】
MEGURO-EKIMAE Branch (518)
Account number: 2129156
3-2-1 Kamiohsaki, Shinagawa-ku, Tokyo, JAPAN
The 31st Annual Meeting of the Japan Society of Gene and Cell Therapy
4-6-1 Shirokanedai, Minato-ku, Tokyo, JAPAN
Chairperson: Takashi Okada

※We will donate the program to companies that sponsor the event.

※The receipt will be the transfer certificate issued by the bank.

※Please note that your company will be responsible for the bank transfer fee.

★If you wish to attend a program other than the seminar co-sponsored by your company, you will need to register separately.

Corporate Exhibition Guidelines

1. Date: From July 23 (Wed) to July 25 (Fri), 2025
2. Venue: Hotel Gajoen Tokyo
(1-8-1 Shimomeguro, Meguro-ku, Tokyo 153-0064; Tel: 03-3491-4111)
3. Delivery: July 22 (Tue), 2025, 7:00 p.m. – 10:00 p.m. (tentative)
4. Exhibits: July 23 (Wed), 2025, 8:00 a.m. – 6:00 p.m. (tentative)
July 24 (Thu), 2025, 8:00 a.m. – 6:00 p.m. (tentative)
July 25 (Fri), 2025, 8:00 a.m. – 12:00 p.m. (tentative)
5. Removal: July 25 (Fri), 2025, 12:00 p.m. – 14:00 p.m. (tentative)
6. Basic booth: The dimensions of the basic booth are shown in the diagram on the right. If special equipment is required, it must be provided by the respective companies.
Back panel [White paper covered, Exhibition desk (width 180 cm × depth 90 cm × height 70 cm) ,
Company name plate]
7. How to apply and deadline: Please send the attached application form via e-mail by no later than April 30 (Wed), 2025.
※Multiple applications are possible.
8. Electricity: Please indicate the desired electrical capacity in the attached application form.
9. Cost of exhibition: 275,000 yen per booth (tax included)
10. Contact:
Secretariat of the 31st Annual Meeting of the Japan Society of Gene and Cell Therapy
Do Convention Inc.
5F, Access Ochanomizu Building, 2-23 Kanda-Awaji-cho, Chiyoda-ku, Tokyo 101-0063
E-mail : jsgct2025-office@umin.ac.jp
Person in charge: Daisuke Kurauchi

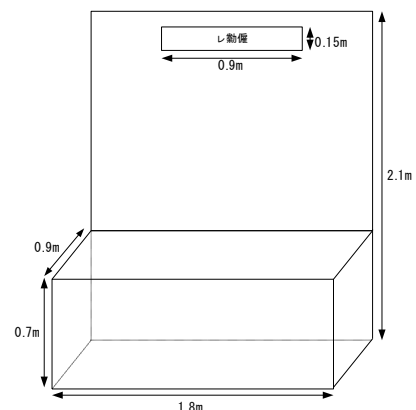

11. Payment account: Resona Bank, Limited
SWIFT code: **【DIWAJPJT】**
MEGURO-EKIMAE Branch (518)
Account number: 2129156

3-2-1 Kamiohsaki, Shinagawa-ku, Tokyo, JAPAN
The 31st Annual Meeting of the Japan Society of Gene and Cell Therapy
4-6-1 Shirokanedai, Minato-ku, Tokyo, JAPAN
Chairperson: Takashi Okada

12. Precautions and other matters:

- A) Exhibitors:
Research equipment, medical equipment, medical supplies, pharmaceuticals, testing equipment, reagents, books, and support and contract services
- B) Exhibition booth:
Booth allocation will be handled by the Society secretariat.
Details regarding booth allocation, delivery, decoration, management, and so forth will be provided approximately one month before the event.
- C) Exhibits:
Exhibits must be within the scope described in the Exhibits section and approved by the Society secretariat.
Please contact the secretariat regarding the exhibition of products that are not approved under the Pharmaceutical Affairs Law.
- D) Prohibition of sales in exhibitions:
The handover of goods in exchange for cash at the exhibits during the event is prohibited.
However, we may permit this on a limited basis for approved items.
- E) Venue management:
We will do our best to protect and manage the venue and exhibits, but we will not be responsible for accidents caused by natural disasters or other unavoidable circumstances, such as theft, loss, or human-caused disasters within the booth. We request that each company take appropriate measures, such as purchasing insurance.
- F) Change of venue and date:
The method, venue, exhibition period, and opening hours may be subject to change due to unavoidable circumstances. Applications cannot be cancelled because of such changes. No compensation will be provided for any damage caused by such changes.
※ To prevent the spread of infectious diseases such as Covid-19, we would appreciate your understanding that the format of the exhibition may be changed to a completely web-based event, depending on the circumstances.
- G) Resale of the exhibition space:
The exhibition space may not be resold or transferred either completely or in part.
- H) Cancellation of the exhibit:
As a rule, exhibitors cannot cancel their applications for participation for their own reasons. Additionally, we cannot refund exhibition fees that have already been paid.

- ※We will donate the program to companies that sponsor the event.
- ※The receipt will be the transfer certificate issued by the bank.
- ※Please note that your company will be responsible for the bank transfer fee.
- ※We are planning to guide visitors to the corporate exhibition space by organizing a stamp rally and other activities in conjunction with the poster presentation area. We would appreciate it if you could prepare novelties and other items for this purpose.

Requests for Advertising in the Pocket Program

1. Printed material: The 31st Annual Meeting of the Japan Society of Gene and Cell Therapy (Pocket Program)
2. Circulation: 1,200 copies
3. Planned publication date: June 2025
4. Distribution target: Participants of the academic meeting
5. Material production fee: 1,500,000 yen (tax included)

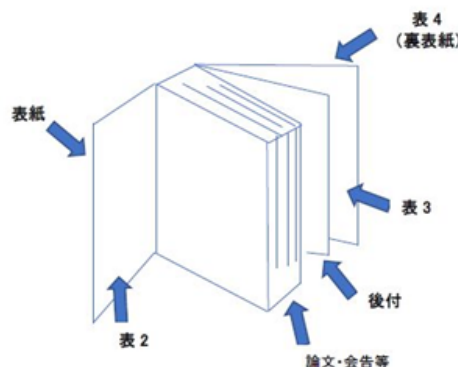

6. Standards and publication fees:

Size and position	Price (tax included)	Number	Color
Surface 4 (B5 size, portrait)	220,000 yen	1	Color
Surface 3 (B5 size, portrait)	165,000 yen	1	Monochrome
Surface 2 (B5 size, portrait)	165,000 yen	1	Monochrome
Appendix, one page (B5 size, portrait)	110,000 yen	5	Monochrome
Appendix half page (B6 size, landscape)	77,000 yen	5	Monochrome

- ▽In the event that a large number of applications are received, surfaces 2, 3, and 4 on the publication page will be allocated on a first-come, first-served basis.
- ▽The location of appendixes in the publication will be left to the organizer to decide.

7. How to apply: Please send the attached application form by e-mail.
8. Application and submission deadline : No later than April 30 (Wed), 2025
9. Advertising copy: Please send the data (text outlined in Illustrator) via email or a storage medium.
10. Contact:
 Secretariat of the 31st Annual Meeting of the Japan Society of Gene and Cell Therapy
 Do Convention Inc.
 5F, Access Ochanomizu Building, 2-23 Kanda-Awaji-cho, Chiyoda city, Tokyo 101-0063
 E-mail: jsgct2025-office@umin.ac.jp
 Person in charge: Daisuke Kurauchi

11. Account for money transfer:

Resona Bank, Limited
 SWIFT code: 【DIWAJPJT】
 MEGURO-EKIMAE Branch (518)
 Account number: 2129156
 3-2-1 Kamiohsaki, Shinagawa-ku, Tokyo, JAPAN
 The 31st Annual Meeting of the Japan Society of Gene and Cell Therapy

4-6-1 Shirokanedai, Minato-ku, Tokyo, JAPAN
Chairperson: Takashi Okada

- ※We will donate the program to companies that sponsor the event.
- ※The receipt will be the transfer certificate issued by the bank.
- ※Please note that your company will be responsible for the bank transfer fee.

Requests for Banner Advertisements on the Conference Website

1. Advertising media : The 31st Annual Meeting of the Japan Society of Gene and Cell Therapy conference homepage
 2. Publication period : From the time of application (image data submission) until closure of the homepage
 3. Placement: At the discretion of the organizer
 4. Number of applicants: 6 companies
 5. Specifications: Please prepare the image data for banner advertisements by your company.
File format: GIF or JPEG (animated GIFs are also acceptable)
Size (pixels): 200 × 70 (may vary slightly)
 6. Listing fee: 110,000 yen (tax included)
 7. How to apply: Please send the attached application form by e-mail.
 8. Method of delivery: Please send the image data and URL link to the secretariat via e-mail.
 9. Contact / Advertising copy delivery address:
Secretariat of the 31st Annual Meeting of the Japan Society of Gene and Cell Therapy
Do Convention Inc.
5F, Access Ochanomizu Building, 2-23 Kanda-Awaji-cho, Chiyoda-ku, Tokyo 101-0063
E-mail : jsgct2025-office@umin.ac.jp
Person in charge: Daisuke Kurauchi
 12. Account for money transfer:
Resona Bank, Limited
SWIFT code: 【DIWAJPJT】
MEGURO-EKIMAE Branch (518)
Account number: 2129156
3-2-1 Kamiohsaki, Shinagawa-ku, Tokyo, JAPAN
The 31st Annual Meeting of the Japan Society of Gene and Cell Therapy
4-6-1 Shirokanedai, Minato-ku, Tokyo, JAPAN
Chairperson: Takashi Okada
- ※We will donate the program to companies that sponsor the event.
※The receipt will be the transfer certificate issued by the bank.
※Please note that your company will be responsible for the bank transfer fee.

Intermission Commercial Broadcast Recruitment Guidelines

1. Advertising media: The 31st Annual Meeting of the Japan Society of Gene and Cell Therapy main screen at the presentation venue
2. Commercial airing period: From July 23 (Wed) to July 25 (Fri), 2025
3. Commercials aired: During the intermission specified by the organizer (~3-4 times daily × 3 days)
4. Number of slots: 5 companies
5. Commercial video specifications: Please create a video file with audio of no more than 15 seconds in MP4 format.
※Still images only are also acceptable.
6. Commercial airing cost: 165,000 yen (tax included)
7. How to send files: Please send the data via post or email (online storage).
8. Application deadline: No later than April 30 (Wed), 2025
9. Contact / Advertising copy delivery address:
Secretariat of the 31st Annual Meeting of the Japan Society of Gene and Cell Therapy
Do Convention Inc.
5F, Access Ochanomizu Building, 2-23 Kanda-Awaji-cho, Chiyoda-ku, Tokyo 101-0063
E-mail: jsgct2025-office@umin.ac.jp
Person in charge: Daisuke Kurauchi
10. Account for money transfer:
Resona Bank, Limited
SWIFT code: **【DIWAJPJT】**
MEGURO-EKIMAE Branch (518)
Account number: 2129156
3-2-1 Kamiohsaki, Shinagawa-ku, Tokyo, JAPAN
The 31st Annual Meeting of the Japan Society of Gene and Cell Therapy
4-6-1 Shirokanedai, Minato-ku, Tokyo, JAPAN
Chairperson: Takashi Okada

- ※We will donate the program to companies that sponsor the event.
- ※The receipt will be the transfer certificate issued by the bank.
- ※Please note that your company will be responsible for the bank transfer fee.

Name Card Holder & Strap Sponsorship

Guidelines

1. Date: From July 23 (Wed) to July 25 (Fri), 2025
2. Venue: Hotel Gajoen Tokyo
(1-8-1 Shimomeguro, Meguro-ku, Tokyo 153-0064; Tel: 03-3491-4111)
3. Quota of participants: 1,000
4. Distribution target: Participants of the academic meeting and related staff
5. Contents: The item in the following image will be used as an official name card holder and strap for participants and related parties on the meeting days.

Illustration	Remarks
	<ul style="list-style-type: none"> • Only one recruitment slot is available. • Please prepare the name card holder and strap at your own expense. • The company logo or company name can be printed on the strap. • Please prepare 1,000 sets, including spares. • The organizers will provide the name card (participation certificate) that will be inserted; therefore, please inform us of the card holder size.

6. Sponsorship: 330,000 yen (tax included)
7. How to apply: Please send the attached application form by e-mail.
8. Application deadline: No later than April 30 (Wed), 2025

11. Account for money transfer:

Resona Bank, Limited
 SWIFT code: 【DIWAJPJT】
 MEGURO-EKIMAE Branch (518)
 Account number: 2129156
 3-2-1 Kamiohsaki, Shinagawa-ku, Tokyo, JAPAN
 The 31st Annual Meeting of the Japan Society of Gene and Cell Therapy
 4-6-1 Shirokanedai, Minato-ku, Tokyo, JAPAN
 Chairperson: Takashi Okada

12. Contact:

Secretariat of the 31st Annual Meeting of the Japan Society of Gene and Cell Therapy
 Do Convention Inc.
 5F, Access Ochanomizu Building, 2-23 Kanda-Awaji-cho, Chiyoda-ku, Tokyo 101-0063
 E-mail: jsgct2025-office@umin.ac.jp
 Person in charge: Daisuke Kurauchi

- ※We will donate the program to companies that sponsor the event.
- ※The receipt will be the transfer certificate issued by the bank.
- ※Please note that your company will be responsible for the bank transfer fee.

Floor Plan of the Venue (proposed use of the venue), Gajoen 2nd Floor

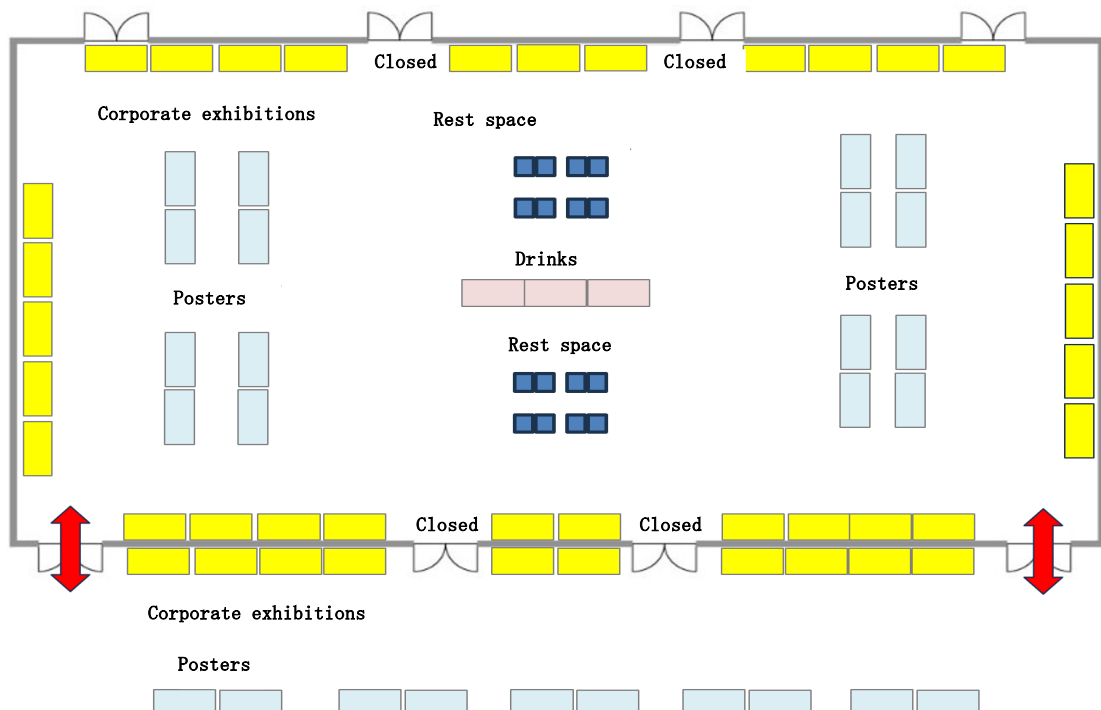
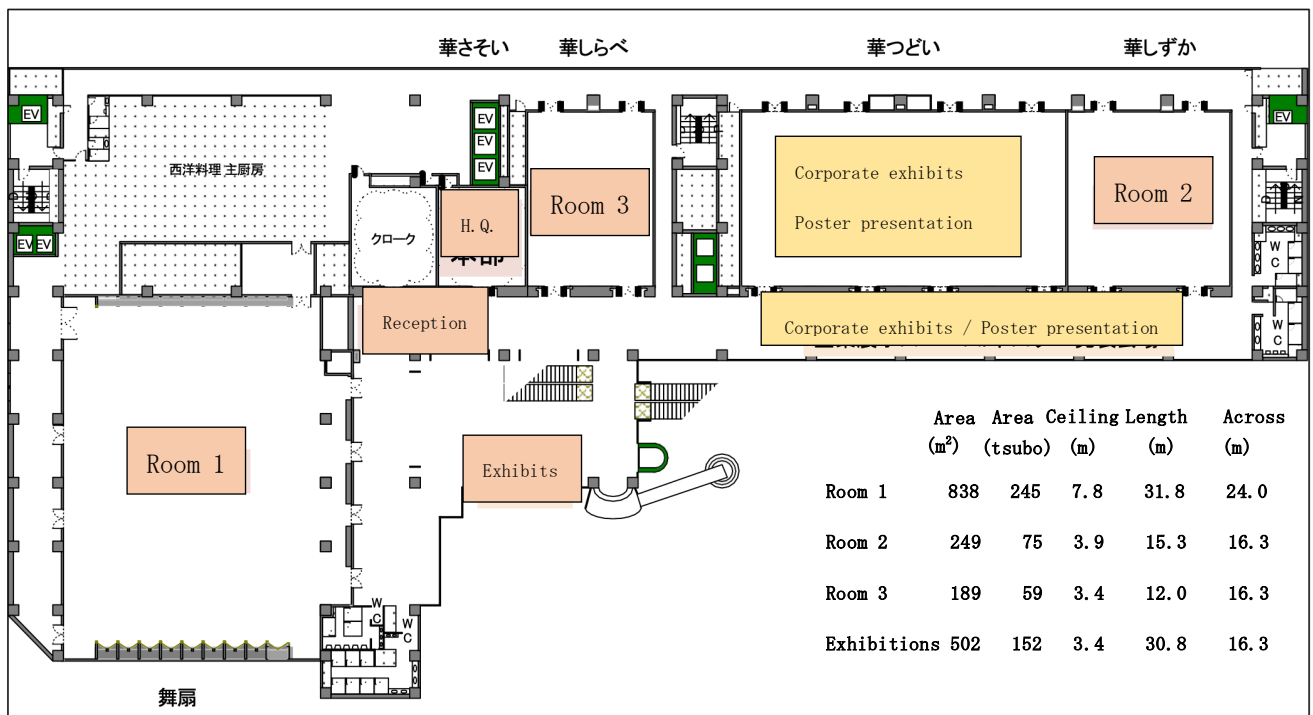

The image above is an example of the exhibition layout (subject to changes depending on the number of exhibitors). Exhibits may also be displayed in the lobby in front of Hall 1.

Donation Application Form

The 31st Annual Meeting of the Japan Society of Gene and Cell Therapy

Chairperson: Takashi Okada

jsgct2025-office@umin.ac.jp (To Do Convention Co., Ltd.)

(1 unit = 100,000 yen)

Amount JPY

I agree with the purpose and apply for the above amount as a sponsorship donation to The 31st Annual Meeting of the Japanese Society of Gene and Cell Therapy.

year month day

Company name:

Person in charge:

Address:

Tel:

E-mail:

Donations will be paid into the designated bank account circa year month.

Application Form for Joint Seminars

The 31st Annual Meeting of the Japan Society of Gene and Cell Therapy

Chairperson: Takashi Okada

jsgct2025-office@umin.ac.jp (To Do Convention Co., Ltd.)

Application date: year month day Deadline: April 30 (Wed), 2025

Name of seminar (Code) :

First choice: _____

Second choice: _____

Third choice: _____

Company name:

Name of person in charge:

Address:

Tel:

E-mail:

Preference for seminar title, chairperson, speaker, and title:

(Coordination of personnel selection with the host: Completed Not completed)

(Acquisition of consent from the speaker chairperson: Completed Not completed)

Invoice:

Qualified Invoicing Business Registration Number Necessary Unnecessary

T3010405020201

Corporate Exhibition Application Form

The 31st Annual Meeting of the Japan Society of Gene and Cell Therapy

Chairperson: Takashi Okada

jsgct2025-office@umin.ac.jp (To Do Convention Co., Ltd.)

Application date: year month day Deadline: April 30 (Wed), 2025

Company name:		
Affiliation:		
Person in charge:		
Address:		
Tel:		
E-mail:		
Basic booth <small>(Back panel, display desk, and company name plate will be prepared)</small>	Space only <small>(Only back panel and company name plate will be prepared)</small>	
Name of exhibit (tentative) :		
【Optional (additional cost)】	Unit price (tax included)	
Spotlight	8,800 yen per pair (2 pieces)	Needed () Pairs Unnecessary
Outlet (100 V/2 parallel outlets)	4,400 yen each	Needed () outlets Unnecessary
Amount of electric power <small>※Installation costs will be charged separately.</small>	5,500 yen per 0.5kw	Needed () Kw Unnecessary
Others (preferences, etc.) :		
Exhibition fee (tax included) : 275,000 yen × () booth		
Invoice :		
Qualified Invoicing Business Registration Number	<input type="checkbox"/> Necessary	<input type="checkbox"/> Unnecessary
T3010405020201		

Advertisement (Pocket Program Banner)

Application Form

The 31st Annual Meeting of the Japan Society of Gene and Cell Therapy

Chairperson: Takashi Okada

jsgct2025-office@umin.ac.jp (To Do Convention Co., Ltd.)

Application date: year month day Deadline: April 30 (Wed), 2025

- | | |
|---|---|
| <input type="checkbox"/> B5 size (Surface 4) 1 page (220,000yen w/tax) | <input type="checkbox"/> B5 Portrait 1 Ad (110,000 yen w/tax) |
| <input type="checkbox"/> B5 size (Surface 3) 1 page (165,000 yen w/tax) | <input type="checkbox"/> B6 Landscape 1 Ad (77,000 yen w/tax) |
| <input type="checkbox"/> B5 size (Surface 2) 1 page (165,000 yen w/tax) | <input type="checkbox"/> Homepage banner 1 banner (110,000 yen w/tax) |

Company name :

Person in charge :

Address:

Tel:

E-mail:

Invoice:

Qualified Invoicing Business Registration Number

T3010405020201

Necessary

Unnecessary

Intermission Commercial Airing Application Form

The 31st Annual Meeting of the Japan Society of Gene and Cell Therapy

Chairperson: Takashi Okada

jsgct2025-office@umin.ac.jp (To Do Convention Co., Ltd.)

Application date : year month day Deadline: June 30 (Mon), 2025

Company name:

Person in charge:

Address:

Tel:

E-mail:

Invoice:

Qualified Invoicing Business Registration Number

T3010405020201

Necessary

Unnecessary

Name Card Holder & Strap Sponsorship Application Form

The 31st Annual Meeting of the Japan Society of Gene and Cell Therapy

Chairperson: Takashi Okada

jsgct2025-office@umin.ac.jp (To Do Convention Co., Ltd.)

Application date: year month day Deadline: April 30 (Wed), 2025

Company name:

Person in charge:

Address:

Tel:

E-mail:

Invoice:

Qualified Invoicing Business Registration Number

T3010405020201

Necessary

Unnecessary